

**AIR EXCHANGE EQUIPMENT
INSTALLATION AND USER MANUAL**



THE QUALITY GOALS OF AIR CONDITIONING COME TRUE WITH THE RECOVERY SYSTEM

TALTERI removes used air from interior and brings in fresh air. Humidity and impurities are exhausted through thermal recovery unit that heats the filtered ambient air cost-effectively. The fresh warm air is channelled draught-free and noise-free into the premises in necessary quantities.

ENSURE THE QUALITY OF AIR EXCHANGE!

THE QUALITY OF LIFE - PURE JOY FROM INTERIOR AIR

The household air exchange systems are classified into five quality categories. By the category means you can choose the level suitable for you (A= ****-stars ... E= * -star). From the quality level C = *** - you have to use air exchange system equipment and parts. The goal numbers will be achieved only by quality monitoring.

TALTERI system with thermal recovery unit will enable better quality levels

TALTERI HEAT RECOVERY AIR VENTILATION SYSTEM (HRV)

SYSTEM COMPONENTS

Figure 1

1. Heat recovery ventilator (HRV). DIVK -700
2. Exhaust fan hood \varnothing \varnothing DX-ULTRA-PT
Exhaust hood \varnothing \varnothing DLT-150
3. Exhaust air outlet \varnothing \varnothing DLVS-200/435
4. Duct silencer \varnothing \varnothing \varnothing \varnothing \varnothing \varnothing \varnothing 200
5. Extract air to the heat recovery ventilator \varnothing \varnothing \varnothing \varnothing \varnothing \varnothing \varnothing ... \varnothing 200
6. Fresh air intake from outdoors. \varnothing 200(250)
7. Fresh air supply to the rooms. \varnothing 200

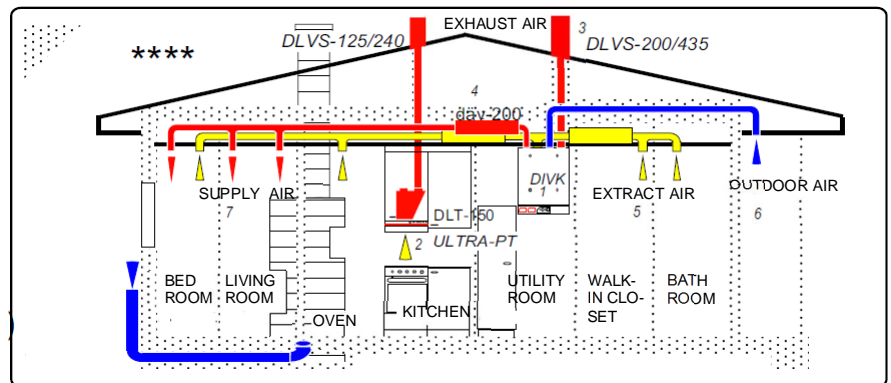

Figure 1: system components

MACHINEPARTSAND TECHNICAL DATA

- 1 Exhaust air out.....200mm
- 2 Outdoor air for the system.....200mm
- 3 Exhaust air for the system.....200mm
- 4 Interior air supply.....200mm
- 5 Electricity connection
- 6 Main switches
- 7 Supply fan, adjustable \varnothing .EC 171W
- 8 Exhaust fan, adjustable.....EC 171W
- 9 Heat exchanger equipped with a bypass damper
- 11 Exhaust/supply air filter....F5 \varnothing F7
- 12 Exhaust of condensing water..... \varnothing 12 mm
- 13 Operating panel
- 16 Summer bypass appliance

POST-HEATING ELECTIC

- 10 Post-heating, adjustable...230V/2000W
- 15 Manual over heat protection

POST-HEATING WATER

17. Post-heating adjustable water battery
18. Post-heating actuator
19. Butterfly plate for the fresh air duct

Dimensions: height 950 mm, width 900 mm, depth 510 mm , weight 80 kg

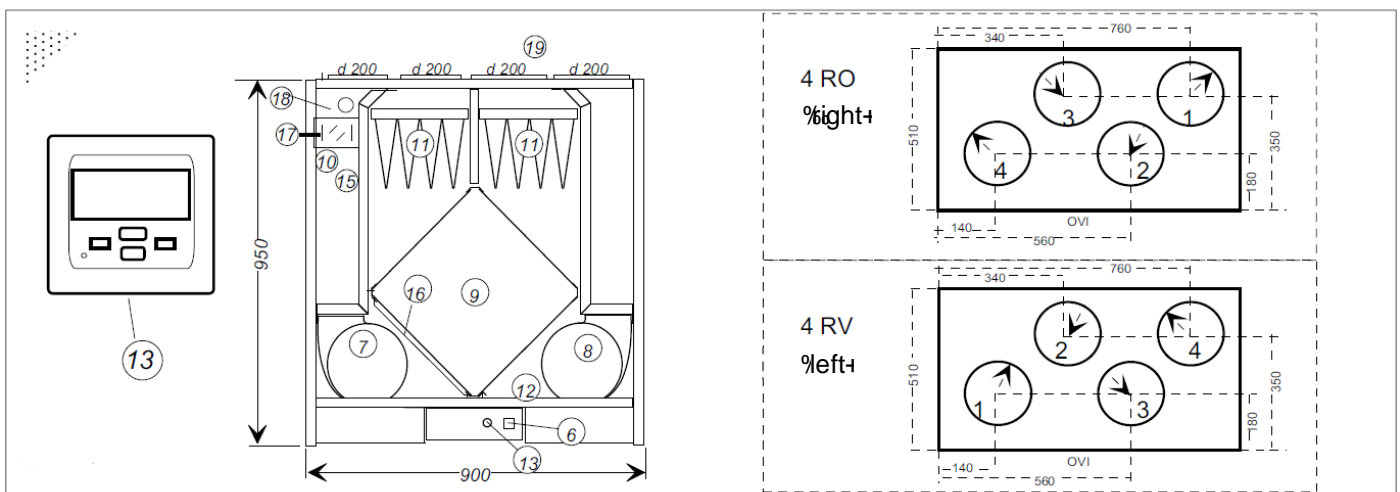

Figure 1: Dimensions DIVK-700

AIR EXCHANGE PLAN

THE AIR EXCHANGE PLAN INCLUDES ATLEAST:

DRAWINGS-plans and sections(1:50)as well as installation drawings(1:20).The drawings must include at least the location of equipment and channels, measures, technical data, air flow and operational chart. For air flow measuring, the installation must be slightly under pressurized.

EQUIPMENT and QUANTITY LIST presents all work-influencing mechanical details with detailed characteristics (equipment list, noise reducers, fans etc).

INSTALLATION MANUAL describes installation procedures for the central engine and equipment. Type approved machinery has detailed installation instructions enclosed to the air exchange plan.

WORK SPECIFICATION specifies contract limits and timetable for the working order. Drawings, lists and installation instructions define IV-work in detail and do not need to be repeated. Work specification defines necessary testings, measuring and basic adjustment with proceedings reports.

THE REQUEST FOR QUOTATION includes total pricing considering on schedule installation according to the plan payment conditions are also extremely important.

IMPLEMENTATION- AND MAINTENANCE TRAINING is unavoidable before the work is ready for handover.

EXTRACT AIR FLOW	Normal operating situation	Basic operating situation
Kitchen	25 dm ³ /s	8 dm ³ /s
Bathroom	15 ‰	10 ‰
WC	10 ‰	7 +
Clothing room	3 ‰	3 ‰
Utility room	15 ‰	8 ‰
Sauna	2 ‰/m ²	6 ‰/m ²
Hobby room	0.5 ‰/m ²	0.5 ‰/m ²
Bed rooms or	0.5 ‰/m ² 6 ‰/person	0.5 ‰/m ² 6 ‰/person

The airflow of the basic operating situation can be used only if it is possible to increase the airflow in the with the control valve to the level of the normal operating situation. A separate exhaust valve is required near the ceiling in the kitchen.

OUTDOOR AIR FLOW

Living room	0.5 dm ³ /s/m ²
Bed room	0.6 ‰ ‰ or 6 dm ³ /s/person
Dining room	0.5 ‰ ‰
Hobby room	0.5 ‰ ‰
Sauna	2 ‰ ‰ at least 6 dm ³ /s

To avoid damages caused by humidity the outdoor airflow has to be at least 85 % of the exhaust airflow.

INSTALLING THE CHANELLING

The channels for exhaust air and incoming air should be installed, if possible, in a warm space below the vapour barrier to suspended ceilings or casing. The vapour barrier remains intact and the channels do not need heat insulation. This also ensures that the airflow in the channels will not freeze due to poor heat insulation as well as there will be no condensing. Cleansing of channels also becomes easier. The outside air and exhaust air channels are isolated under warm conditions, see the instructions.

The channels are compiled of type-approved, rubber gasket parts and wined joint channel. Disconnections will be removed for sealing and noise reasons. Connections will be secured with closing drawstrings and channels attached securely to the framework with mounting strings so it will persist also cleaning.

Measuring- and regulation equipment of airflow are installed to exhaust channels after noise deductors and inflow channels before the deductors. For cleansing, a cleansing hatch should be installed. Remember, that a good functioning channel is: measured correctly, hermetic, carefully attached, properly isolated and with hermetic inlets!

THE SYSTEM IS ONLY AS GOOD AS IT'S WEAKEST PART!

CHANNEL ISOLATION

Since the channels are mounted to the upper base, it must be carefully isolated so that: humidity will not condensate on pipe surfaces, the air will not freeze before heat has been stored, the heated incoming air will not freeze before it is blown into interior.

The two main rules of channel isolation are:

The warm air channels are always isolated in outer conditions with at least 10 cm of mineral wool and windscreen plating. The cold air channels are always isolated in inside premises with 10 cm of mineral wool and steam barrier plating, for instance AE-chase or AIM-mat. (Figure 2)

CHANNELS OF OUTSIDE- AND EXHAUST AIR

The outside air will be obtained through 200 mm grate without an insect net. The air inlet will be situated to as clean space as possible, far from the refuse discharge, smokestack, ventilation outlet and exhaust air tube. The air inlet will be located to a height of at least 2 meters from ground on the northern side of the building, opposite side to the traffic.

Due to warm summer weather, the outlet channel has to be thermally isolated in a loft space. Outgoing exhaust air will be channelled above the rooftop through well-isolated channel and by 700-900mm high isolated roof duct. (Figure 3).

Fireplaces like hearths, ovens and sauna heating systems must have a separate isolated combustion air channels with slide coping.

INSTALLATION OF VENTS

Income and outlet vents are installed according to the plan. Special attention is needed while installing income valve since a wrong vent in a wrong place and wrong mounting will affect the air draught and reduce satisfaction.

Steam barriers are well tightened.

In saunas, the income air is channelled above the sauna stove and outlet will be taken from underneath the sauna platform. The sauna vents are manually adjustable.

In kitchens, the outlet appliance should be the stove hood with adjustment plate of three positions and an airflow gauge. The exhaust vent is operated by the means of the adjuster. The kitchen exhaust will be attached to the air exchange unit.

In case sound isolation is needed between the separate rooms, cushioned air transfer vents are used, figure 4. Air transfer routes in doorways and under the doors will greatly reduce the privacy.

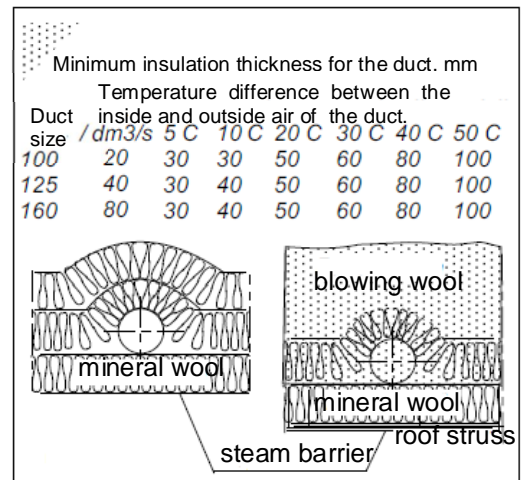

Figure 2 Channel isolation

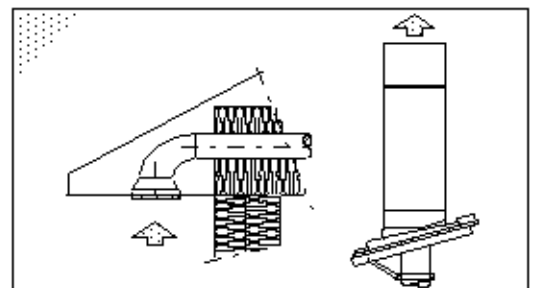

Figure 3: Outside and exhaust air inlets.

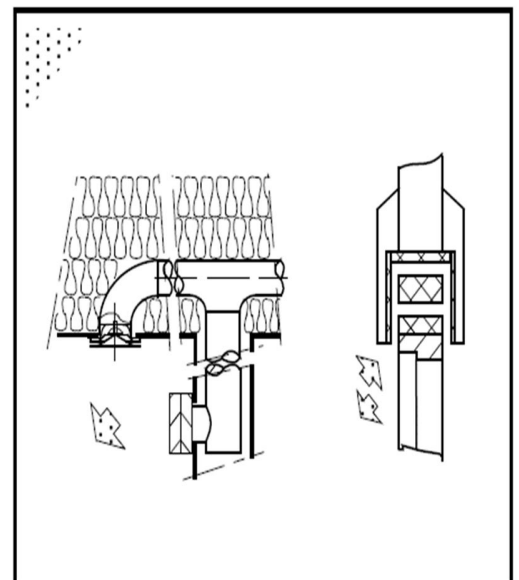

Figure 4: Supply and transfer air vents.

TALTERI DIVK-700 INSTALLATION

The air exchange unit is meant for warm inner facilities. Suitable installation spots are, among others, office, dressing or household facilities and technical or warm storages. In case the temperature of the installation location is lower than room temperature, the factory settings of the appliance must be changed to obtain faultless functioning. The unit can not be installed into cold outer premises or garages. Exhaust of condensing water proceeds through a water-sealed joint hose into a washing basin or dry+floor well. Check the horizontal position of the unit and free flow of the condensing water.

The unit can be mounted on a wall with corner trims, which should be attached with M8 screws to the rivet nuts on the sidewalls of the unit. To install the unit on the floor, attach the 150 mm high plinth legs (available as accessories) to the bottom of the unit with M8 screws. Raising the unit above the floor leaves space for the condensate water hose and the power cord. The unit can be attached also to the ceiling with threaded bars or with plinth legs, which should be attached to the rivet nuts on the top of the unit.

The outlet hose of condensing water has readily installed water-sealed rising joint that can be taken right into the wall sewerage. Check that the hose is not pressed together. There must be only one water-sealed joint between the appliance and sewerage.

ELECTRICAL CONNECTIONS

Electrical connections must be done following the installation manual and wiring scheme.

ELECTRICAL CONNECTIONS CAN BE DONE ONLY BY AN ENTREPRENEUR WITH RESPECTIVE INSTALLATION RIGHTS.

Electrical connection box can be opened from the front side below the unit by removing the screws beneath the locking covers. The connection box slides out by pulling it forward up to the end stop guide.

DIVK-700 DE is connected to an electrical socket with a 3x2,5 power cord. If the unit is equipped with a pre-heater, a 4x2,5 power cord should be used instead of a 3x2,5 power cord.

The cable connecting the unit to a pre-heater is coming from the unit's electrical box through the bottom entry of the unit located near its backside

The operating panel is connected to the control board by modular connector.

The following can be connected as accessories:

- Carbon dioxide transmitter
- Humidity transmitter
- Separate Overload or Extended Period switch (pulse switch)
- Separate Boost switch (pulse switch) or setting off as pre-data (for instance, sauna oven, stove hood)
- Remote control or out-of-home switches (pre-data)
- Differential pressure switches for filters
- Outside pre-heating

The functions can be operated through maintenance - and setup menus of the operating panel.

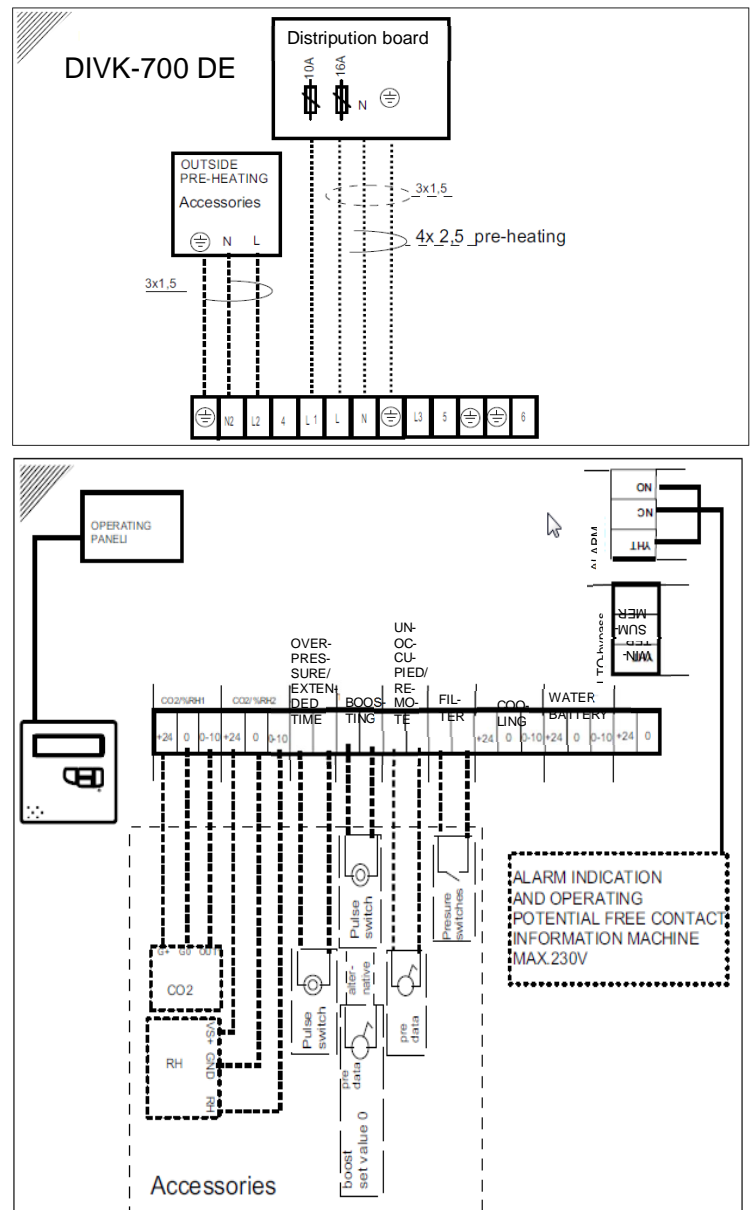
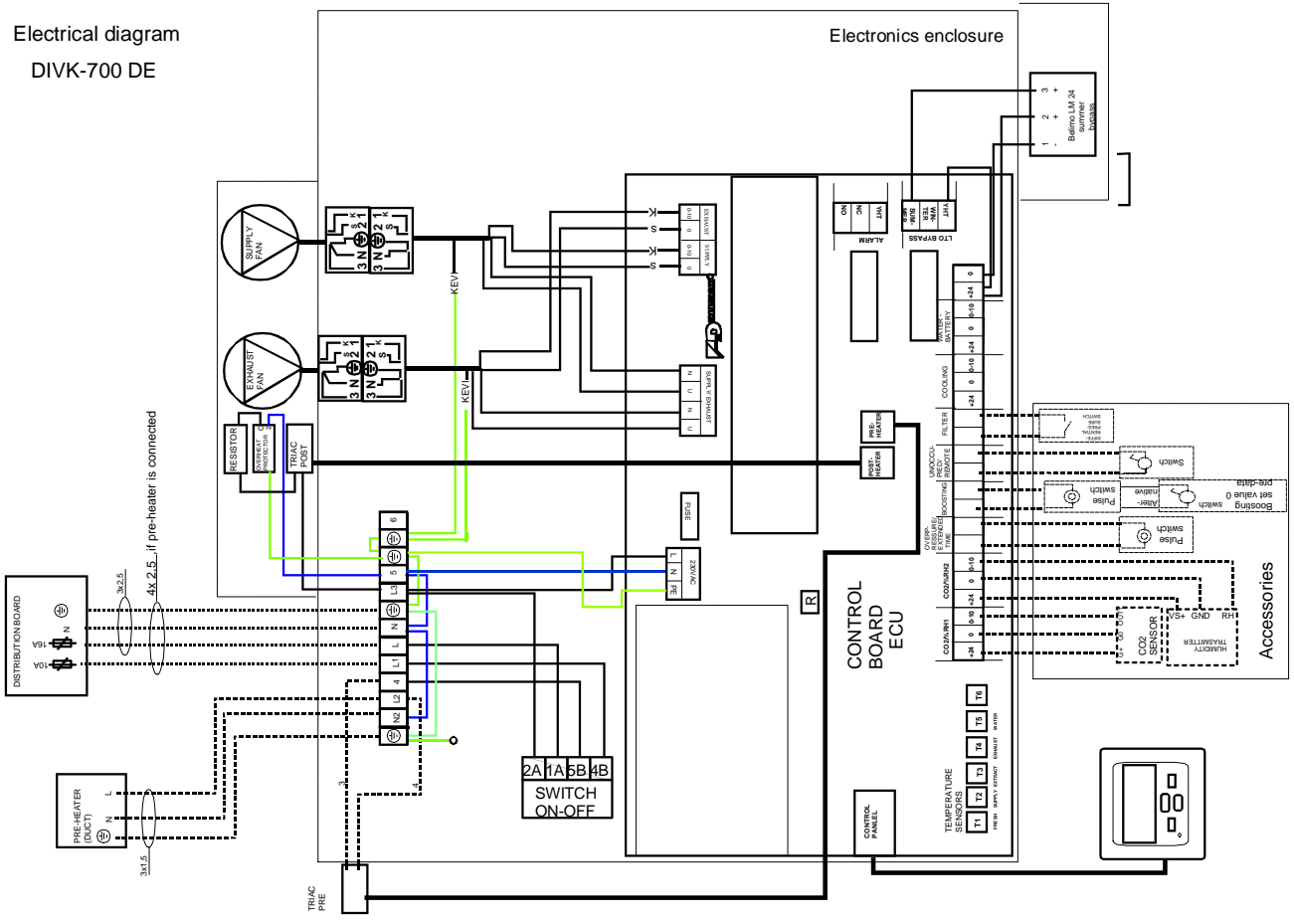

Figure 5: Electrical connections

Electrical diagram
DIVK-700 DE



Electrical diagram
DIVK-700DE VKL

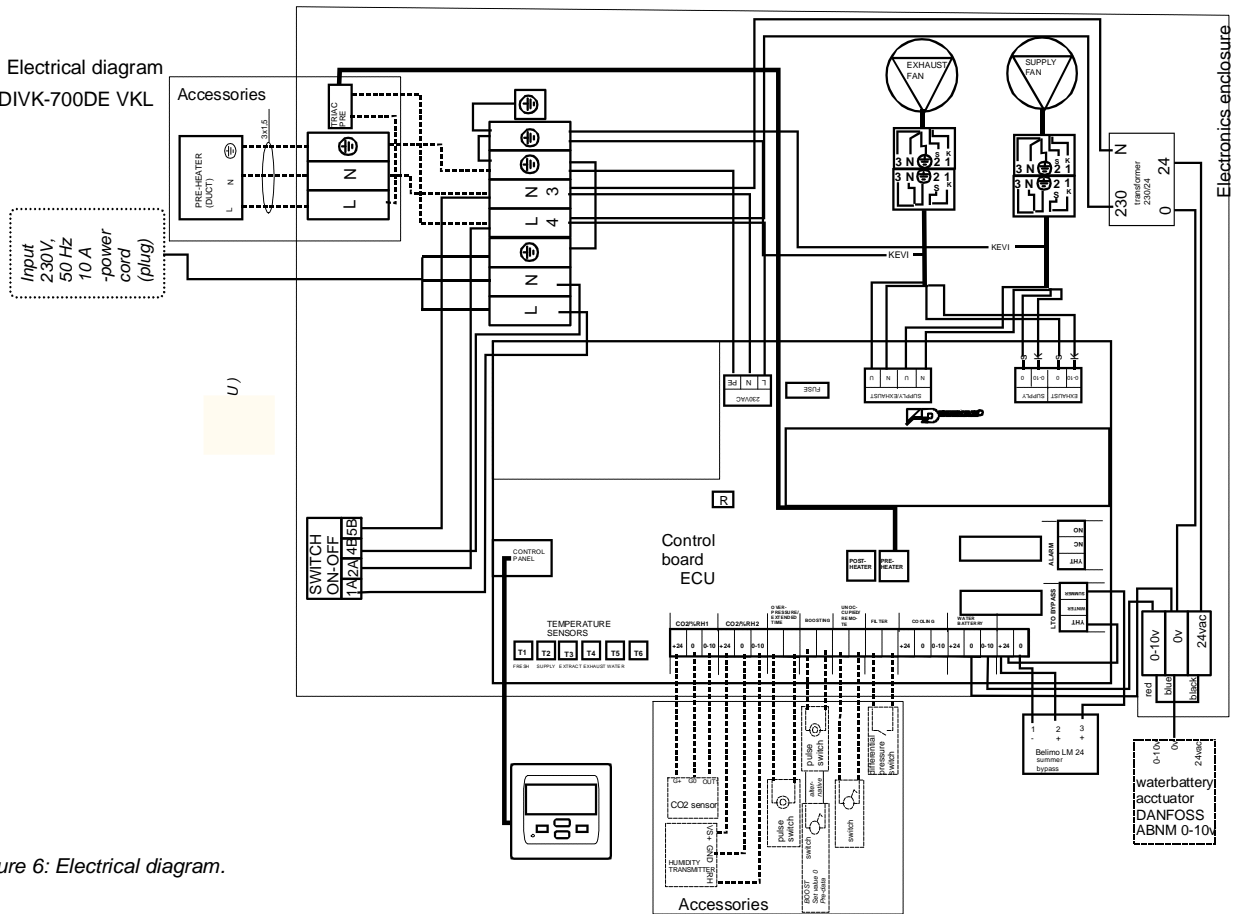

Figure 6: Electrical diagram.

Operator panel bezel removal



Figure 7: Operator bezel removal

With water battery (VKL) installation it should be observed

- The designing must consider temperature of used water and sustainability of the heating power under rated conditions.
- Water, reaching the appliance, must be pre-regulated after leaving the boiler.
- Post-heating battery is switched to the appliance from inside by a respective copper or plastic hose.
- The water flowing into the heating battery is connected to the operating appliance (3/8 female screw) that regulates the water flow into the battery.
- The return water of the battery is connected by 10mm pressure-connector and air fan is mounted to the highest point of the hose.
- Locking fans are mounted to the outlet as well as return hoses.
- The water battery is equipped with an anti-freeze thermostat that stops the inlet air impeller in case the temperature of the water battery decreases below the limit value (approximately +10c). In such a case the self-powered butterfly plate also closes and prevents the cold outside air from entering into the battery. The axel of the butterfly plate must be in a vertical position.

Table 1: Water battery sizing chart

water battery sizing chart					
coming water	return water	water flow	air flow	rise of the temperature	total power
70c	40c	108l/h	80l/h	-5/38	4.1 kW
70c	34c	108l/h	120l/h	-5/30	5.0 kW
50c	28c	108l/h	80l/h	-5/27	3.1 kW
50c	24c	108l/h	120l/h	-5/21	3.7 kW
35c	23c	108l/h	50l/h	-5/23	1.7 kW
35c	22c	108l/h	60l/h	-5/21	1.9 kW

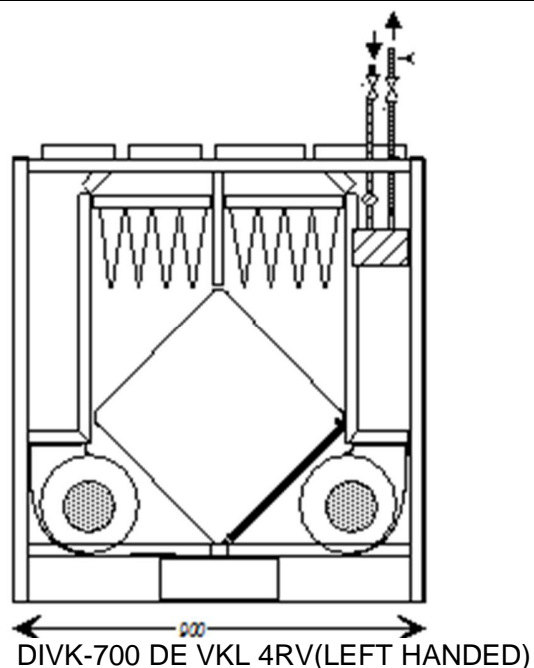
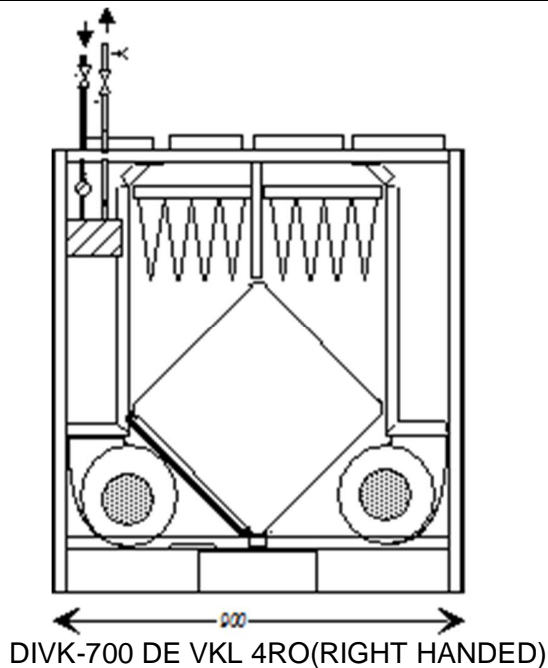

AIRVOLUMES

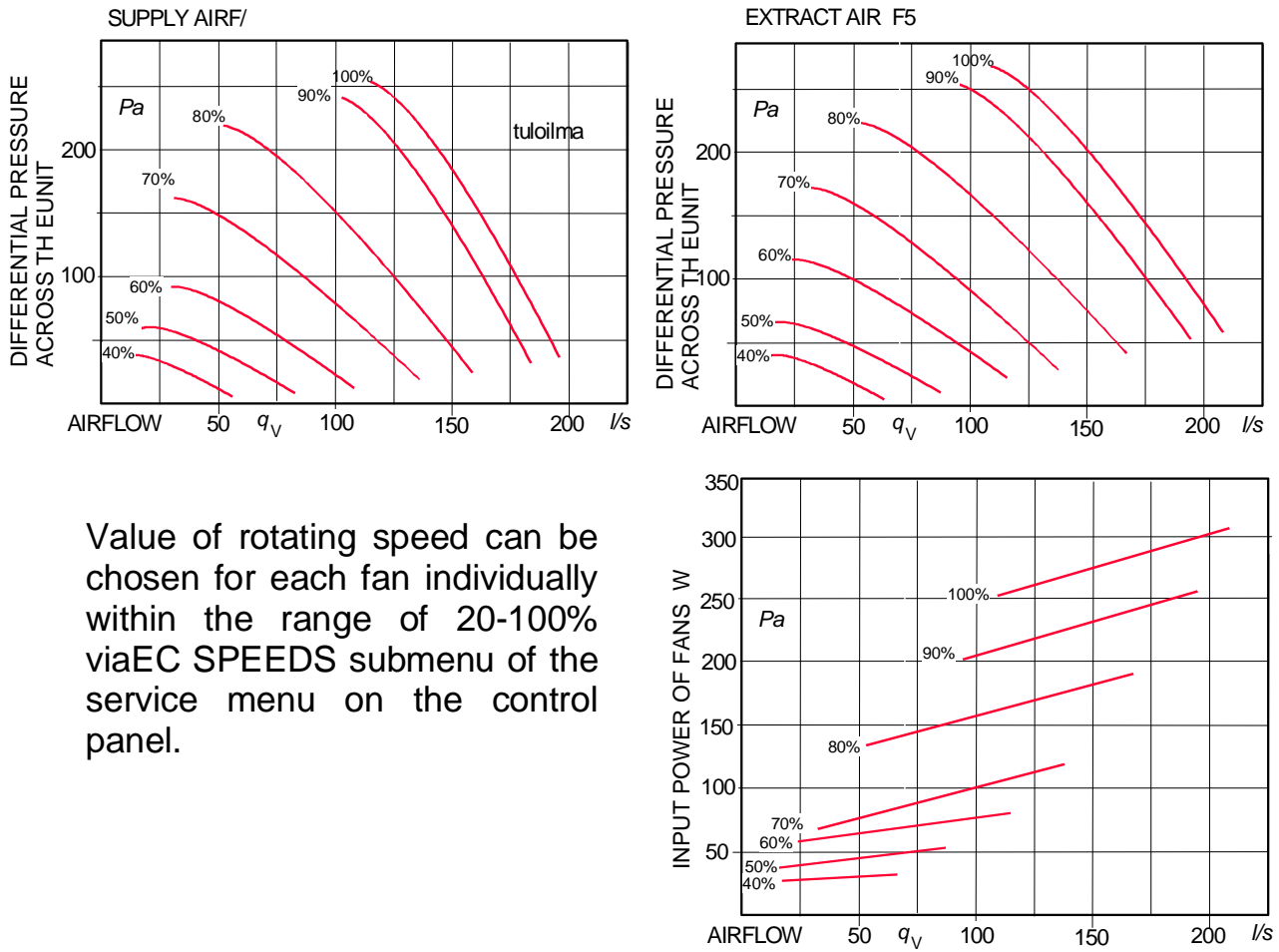

Value of rotating speed can be chosen for each fan individually within the range of 20-100% via EC SPEEDS submenu of the service menu on the control panel.

SOUNDVALUES

Fan speed	%	40	50	60	70	80	90	100
Input power of fans	W	20	49	75	116	181	255	308
Airflow	E/S	40/35	65/58	87/77	120/105	148/142	170/165	187/181
Sound pressure level in installation premises	dB(A)	24	29	34	38	41	44	46
Weighted sound pressure levels	Hz	E S	E S	E S	E S	E S	E S	E S
	63	36 43	41 50	45 53	48 56	50 58	54 60	55 62
	125	38 42	43 48	47 52	51 56	53 58	57 61	58 62
L_w of exhaust(E) and supply(S) ducts on different octave bands	250	32 40	36 46	42 50	45 55	49 58	52 61	54 62
	500	27 42	32 49	37 52	41 56	44 58	47 62	49 63
	1000	24 41	30 49	34 54	38 57	41 60	44 63	46 64
	2000	19 34	26 43	32 50	36 55	39 60	43 64	44 65
	4000	* 24	13 34	18 43	23 49	27 53	32 57	34 59
	8000	* 11	* 19	* 28	11 35	13 41	23 46	21 48
Total output	L_{WA}	28 43	40 50	44 56	43 60	46 64	49 67	51 69

Figure 8 Air flow and sound pressure values

INTRODUCTION OF THE AIR EXCHANGE

BEFORE OPERATING YOUR AIR EXCHANGE SYSTEM, MAKE SURE THAT:

- There are no loose objects within the unit or the air impeller. Screws or any other objects inside the fans can cause damage when the unit is switched on;
- flexible mounting of fans is used to ensure their free swinging ;
- The coverings of construction-time are removed from the outlet- and exhaust air holes.
- All isolations and steam barriers are in order;
- heat exchanger is in place and the summer bypass plate is in the winter position: air is flowing through the heat exchanger and the bypass tunnel behind the heat exchanger is closed;
- filter bags are in place and tightly secured with springs to the silicon sealing to avoid a bypass flow;
- noise deductors are in place in the pressure chambers located above the fans;
- The condensing water outlet is installed and the water is drained out; test it by pouring small amount of water in the condensate basin;
- The air impellers and their adjusters are in working order
 - Post-heating is regulated and working Ensure that the overheat protector is reset if it has been activated;
- necessary settings have been configured through the maintenance and settings menu on the unit's control panel.

USAGE DURING INSTALLING

The air exchange unit should be started as soon as installation permits. Efficient air exchange promotes drying of the constructions and prevents damage. In case channeling has not been completed, fans and adjustments are missing, filter paper must be used in place of fans to keep the channels clean and provide sufficient counter pressure preventing overload. The unit must be used with full power and check the drainage of the condensing water. The appliance, filters and heat exchangers must be cleaned and the system adjusted after the construction works are completed. The inner painted walls of the unit are easy to clean

BASIC ADJUSTMENT OF AIRFLOW

The unit alone can not produce good interior air in case the channels and fans are installed carelessly and main adjustments are not made. Regulate the inlet and outlet fans to the planned positions and start the unit at design power speed. Measure the airflow in outside- and exhaust air channels. The outlet must be 10-15% higher than inlet. Check the pressure level of the channels by checking from the fans and adjust it accordingly to obtain the pressure level of 10-30 Pa for fans adjust and lock the pattern. Draw measuring- and adjustment records!

USAGE AND CORRECT LEVEL OF AIR EXCHANGE

The air exchange level is regulated by changing the working speed of the air impeller from the operating panel. Airflow of different adjustable positions can be seen from figure 5.

Adjustable position 1 is for basic air exchange for an empty house.

Adjustable position 2 and 3 are normal working positions.

Adjustable position 4 and 5 are efficiency positions (i.e. for saunas).

The correct usage positions will be found by experience observing the purity of the air or sultriness when coming in from outside, observing moisture on the windows or drying of the sauna.

POST-HEATING AND SUMMER BYPASS OF INLET AIR

DIVK-700 DE is equipped with 2000W electrical battery operated by the means of TRIAC-adjuster or a water battery (VKL) operated by the operating device for post-heating the heat recovered inlet air.

The temperature of inlet air is usually regulated to +16C.

The temperature may be adjusted to higher during winter so there would be no draught like feeling. In case of severe frost and efficiency mode the heating power might turn out insufficient in such circumstances, the air exchange should be reduced .

The overheat protection has been activated in case the barrier temperature has risen +90 C (for instance, in case of power failure). Reset the overheat temperature by pressing the switch under the threaded contact protection.

During summertime, the Ito-exchanger element on the bypass plate will be closed so the exhaust air will not warm up the inlet air.

For summer time it is recommended to install EU.7 bag filter, which efficiently filters pollen and other fine particles among others.

CONDENSING WATER AND FREEZING PREVENTION

When outlet air freezes, the humidity in Ito-exchanger turns into water, flows down to the condensing basin and from there, through the hose and water trap, into the open drain. During very cold weather the water would freeze into the exchanger unless the anti-freezing thermostat stops the inlet air impeller for the fusion period. During severe cold, the inlet air impeller will work in cycles. Under extreme conditions (humidity /harsh cold) the Ito-element may freeze over and the anti-freeze protection series are not able to defrost it. If such a case occurs, the machine has to be stopped, opened and the cold flow stopped and the ice given the necessary time to melt. Check the drainage of condensed water!
+Waste air cold+ setting of the freeze protection thermostat can be adjusted through the service menu on the unit's control panel.

OPERATING PANEL USER INSTRUCTIONS

MAIN DISPLAY AND ADJUSTMENT OF BLOWING SPEED

CLOCK
THE DISPLAY ALSO
SHOWS POSSIBLE
INCREASED EFFICIENCY AND
MALFUNCTIONS

HUMIDITY AND CARBON
DIOXIDE VALUE
IF SENSORS ARE INSTALLED
(accessory equipment)

TEMPERATURE DISPLAY FOR
TEMPERATURE OF OUTSIDE AIR,
INCOME AIR, OUTLET AIR AND
EXHAUST AIR
ACCURACY OF TEMPERATURE
SENSORS +2c

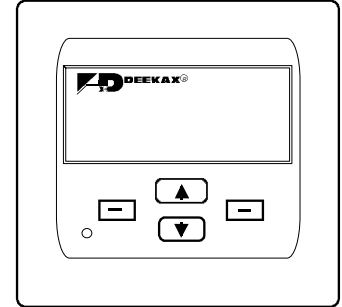
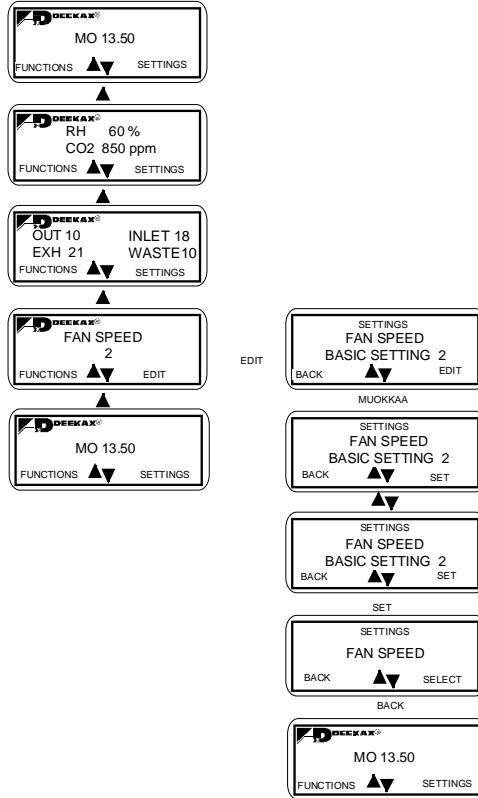

LED OPERATION	REASON
BLINKING RED	SENSOR FAULT RETURN WATER GOLD
RED	INCOMING AIR GOLD INCOMING AIR HOT
BLINKING YELLOW	FILTER PRESSURE- CAP SWITCH MAINTENANCE INTERVAL REMINDER WASTE AIR COLD
YELLOW	OUT-OF-HOUSE SWITCH OVER-PRESSURE ACTIVATED INTENSIFICATION ACTIVATE CO2/RH INTENSIFICATION ACTIVATE WASTE AIR COLD
BLINKING GREEN	PRE-HEATING ACTIVATE
GREEN	AFTERHEATING OR AFTERCOOLING ACTIVATED

ACTIVATING/DEACTIVATING OVERPRESSURE, INTENSIFICATION AND AFTERHEATING

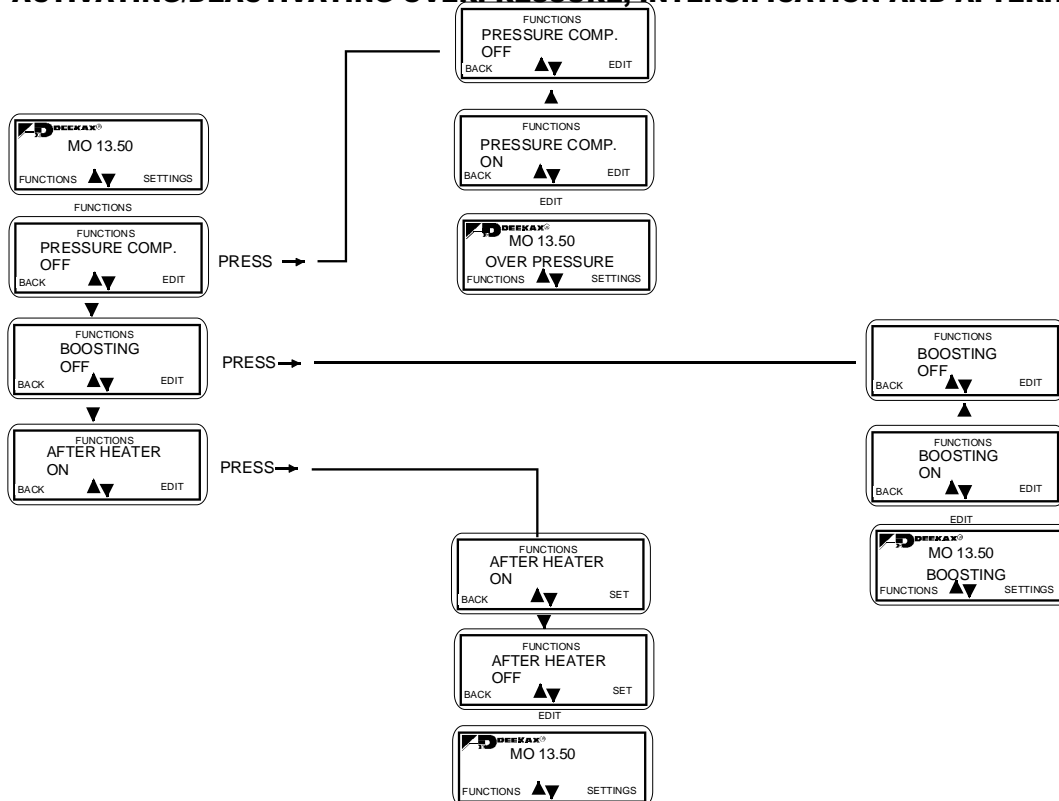

SETUP MENU

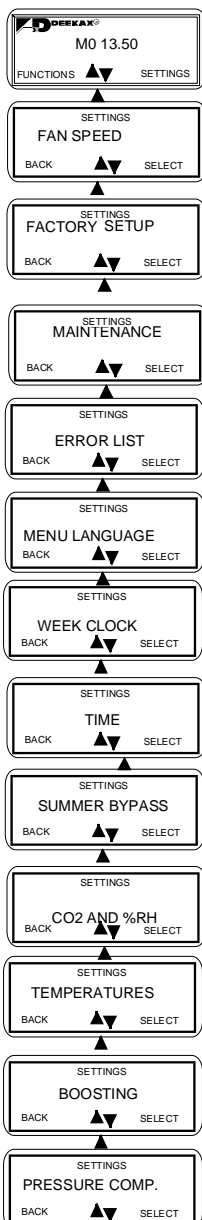
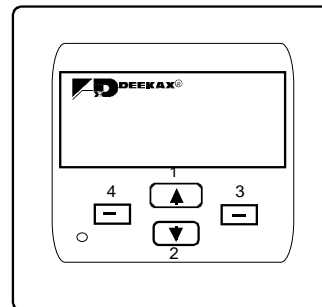

Fan speed adjustment 1...5

Maintenance interval and reset

Display sensor and overheating faults, temperature deviations, filter exchange and starts Fault list reset

Selecting language suomi, svenska, english or eesti

Air exchange can be reduced/increased during selected time periods. 5 different periods can be programmed. Each time period can be set for one or several weekdays. In office-mode, the unit stops for the period out of selection and display reads standby.

Weekday and clock selection

Operating the summer bypass. The user of the unit can set the bypass plate manually to SUMMER/WINTER or AUTOMATIC mode

In summer mode the bypass plate is activated

During the automatic mode, the plate works according to outside temperature. Set value 15...20c

The automatic mode has adjustment amplitude of approx 2 hours

CO2 transmitter ON/OFF switching. Setting of CO2 upper limit. Set value 250...1500ppm, 50ppm steps

%RH transmitter ON/OFF switching. Setting of RH upper limit. Set value 30...80%, 5% steps

Regulating amplitude 5...20min

Regulation of inlet air afterheating set value 1 5...30c

Set value of intensification duration 0 and 5...120min. In 0 position different switch

Set value of overpressure duration time (hearth switch) 5...30min

KEYBOARD

1. The push button can be used to browse menu upwards and change setting values.

2. The push button can be used to browse menu upwards and change setting values.

3. Function selection and recording switch.

4. Return to previous or main menu.

MAINTENANCE MENU

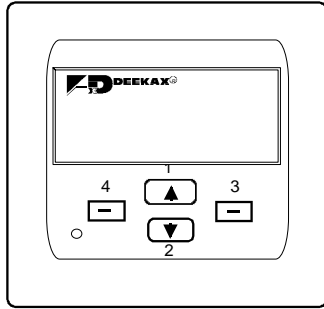

KEYBOARD

1. The push button can be used to browse menu upwards and change setting values.
2. The push button can be used to browse menu upwards and change setting values.
3. Function selection and recording switch.
4. Return to previous or main menu.

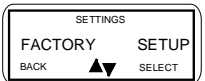
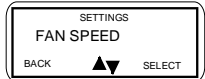
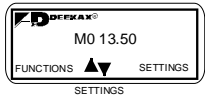

press about 5 sec



HOME: overpressure activated
OFFICE: continuation time activated



Return to default settings
(NOTE! VLK units post-heating function must be switched on from the service menu)



Recording must be done always after the maintenance set values have been changed



Startup with remote control or separate switch; remote control ON+the unit operates only if pre-data is switched on
OR
Out-of-house mode
remote control off+the unit operates on minimum speed with pre-data switched on



Usable if the differential-pressure switch is present



Maintenance interval reminder settings 0-12 months



Office-mode continuation time setting 30...120min
Usable with separate pulse-switch if the weekly clock is used in office-mode

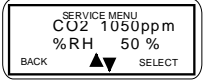

CO2 and humidity percentage setting



CO₂ and/or RH sensors activation



Inlet air heating temperature 30...40c



Inlet air cooling temperature 10...15c



Freeze-alert settings 0-10c



Anti-freeze appliance control



Pre-heating activation



Regulation of VKL-appliance water battery backup-sensor
Set values 0 and 5...10c, 0 : deactivated



Afterheating selection ELECTRICITY or WATER

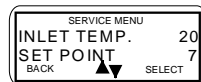

Regulation of Inlet Air and Pre-heating value
The value of pre-heating should be regulated to be approx 5c higher than the limit of cold exhaust air

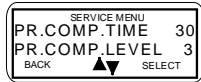

Overpressure duration specification 5...20min
Overpressure limit regulation 1...4 (inlet air impeller higher than outlet air impeller)



Intensification time settings 5...120min
Intensification limit settings 1...4 (the air impellers higher than basic speed)



Speed control of the fans.
There are five fan speed modes which can be adjusted individually within the range of 20-100%.



Running speed difference of inlet and outlet air impellers
0 Air impellers working simultaneously
-1 Inlet air impeller runs 1 step faster than the outlet air impeller
1 outlet air impeller runs 1 step faster than the inlet air impeller
ATTENTION! If air impellers run on different speed, appliance has 4 basic speeds

OPERATING PANEL USER INSTRUCTIONS

1. Operating panel

The appliance is operated by the means of the operating panel that has four buttons and alphanumeric display with 2x16 indicator lights.

The operation is directed according to settings inserted by the user or installer/manufacturer through the operating panel as well as according to temperature sensors and set periods.

The operating panel returns from processing state to basic state 30 seconds after the last button pressing. The return time from normal position is 10 seconds. The background lights of the operating panel will turn off.

Restoring factory settings function on the operating panel -end-users settings will be restored to default factory settings.

Maintenance menu - for setting suitable parameters for the installation. Maintenance menu is hidden from the end-user. - Restoring factory settings- option is also present in the maintenance menu that can be used for turning all settings (user settings and maintenance menu) to default settings.

The user can use four different selections on the operating panel: weekday and time, blowing speeds, temperatures and air quality values in case there are sensors for these functions.

2. Operating card

The operating card manages the unit-s functions according to user-selections and measuring data received from the sensors. The operating card has additionally two transmitter inputs for %RH or CO₂ connections, 4 switch data inputs and five-speed outputs for two EC air impellers. The operation pane is connected with the operation card by four-polar modular connector.

3. Controlling of the air impellers

3.1. Speed controlling in default state

Inlet and outlet impellers have 5 speeds. The suitable ones can be selected from service menu of the control panel within the range of 20-100% depending on the working conditions. Impeller speeds are selectable by the user. The speeds are set to factory defaults in the maintenance menu and the unit starts with factory speeds.

3.2. Overpressurization

Overpressurization state selectable from the outer switch or operation panel. Outlet impeller is set on minimum, inlet impeller is set to value of the maintenance menu. The intensifications have no impact at this point. The duration of overpressurization in minutes is selectable by the user. New push from the switch launches overpressurization from the beginning. Overpressurization can be shut down also from operating panel. Anti-freeze is deactivated when overpressurization is switched on.

3.3. Intensification

Intensification of air exchange can be activated from the operating panel or stove hood. Activation from the panel sets the durability of intensification in minutes (5...120min). Maintenance menu is used to set the quantity and default time. In this case, CO₂/%RH intensification has no impact. Intensification is activated also according to external data.

3.4. CO₂- and %RH- intensification

CO₂ - transmitter or data given by the transmitter is the basis for air exchange intensification in regulating intervals. The CO₂ maximum limits are set from the panel by the user (250-1500ppm, 50ppm steps). CO₂ measuring values can be seen on the operating panel. The air exchange is periodically intensified by data of %RH - transmitter or transmitters. The maximum limits of relative humidity are set from the panel by the user (30-80%, 5% steps). %RH measuring values can be seen on the operating panel. The card has two transmitter inputs that can be chosen separately for CO₂ or %RH activation and deactivation. Regulation interval is a parameter set through the maintenance menu that determines how often the impeller speed can change in intensification mode. Set value 5-20 minutes by 1 minute. The regulation interval is same for both CO₂- and % RH intensification.

3.5. Out-of-house function

The -out-of-house- function can be selected from the external switch, the impellers are set on minimum speed. However, previously set intensification or overpressurization will be completed before the impeller speed is reduced or stopped altogether.

3.6. Weekly clock

The program selectable by the user enables to reduce/increase air exchange during selected periods of time. 5 different time periods can be programmed at the same time. Each time period can be set with one or several weekdays.

3.7. Office mode

The installer can select the office mode from the maintenance menu - this is useful in case the air exchange system is installed into an office where activities take place mostly during daytime.

The mode is equipped with continuation switch that enables persons who remain in the office for longer to prolong the functioning of the appliance by set interval. Intensification and out-of-house mode functions are not usable in the office mode.

Remote control mode can also be selected from the maintenance menu that enables to switch the unit on and off by the mean of pre-programmed data and weekly clock functions are deactivated.

4. Setting the temperature

Temperature is measured from four different sources: temperature outside, inlet temperature, outlet temperature and exhaust air temperature. The temperatures are displayed on the operating panel. The precision of measurement is +/- 1 degree.

4.1. Post-heating

The thermostat leads the post-heater located in the inlet channel. The heater can be electrical or water heater and is selected by the installer from the maintenance menu. The heater keeps inlet air at the exact temperature selected by the user. The desired temperature can be set from the operating panel. Set values are between 15 - 30 degrees.

4.2. Preheating

Preheater is an electric heater located in the outlet channel. The preheater's thermostat is driven based on the temperature of exhaust air. Preheating is meant for prevent freezing of the recovered heat. The temperature setting of the thermostat can be selected by the installer from the maintenance menu with limitations of 0 - 10 degrees.

4.3. Summer cassette function

The unit is equipped with summer cassette for heat exchange during summertime. The user can select the function manually or let the functioning be determined automatically according to the temperature outside. During the Summer mode, the bypass plate of the cassette is activated.

The automatic functioning can be set with external temperature between 15 - 20 degrees.

5. Alarms and reminders

5.1. Activation of overheat protection

Information on activation of overheats protection connected to electrical post-heater and preheater is received from the heater. In case the protection launches, the impellers are automatically set on minimum speed, red indicator light blinks on the operating panel and the display informs about malfunctioning.

5.2. Inlet air too cold

Inlet air minimum temperature must be set from the maintenance menu. When the air temperature is lower than set, the information will be displayed on operating panel and red indication light is turned on. The inlet impeller is stopped and the speed of outlet impeller is reduced to minimum. These actions prevent the water-circulation battery from freezing.

5.3. Inlet air too hot

Maximum limit of inlet air temperature must be set from the maintenance menu. When the air temperature exceeds the set limits, respective information will be displayed on operating panel and red indication light is turned on. The inlet impeller is stopped and the speed of outlet impeller decreased to minimum.

5.4. Exhaust air too cold

The exhaust air temperature minimum limits must be set from the maintenance menu (0-10 degrees). When the air temperature is lower, warning is displayed on the operating panel and red indication light is turned on. The temperature is attempted to keep above the set value by reducing the speed of inlet air impeller (see also preheating) by regulating it one-step at a time. In case the air temperature does not rise over the alarm limit even when the impeller is completely stopped, the red indication light starts to blink and freezing alert is displayed. In case the temperature is restored to normal, normal functioning will be also restored by increasing the impeller speed one-step at a time.

5.5 Danger of freezing the water battery

The lower temperature limit for the return water can be set by adjusting value of the +RADIATOR RETURN MIN TEMP+ setting in the service menu of the VKL-units. If the return water temperature slides below the limit, a textual alert and red indication light are displayed on the operator panel.

5.6 Alarms to the remote control room

Should any of the following issues occur, general alarm signals are sent from the HRV potential free relay to the remote control room. Issues that can trigger an alarm: Inlet air too hot or cold, danger of freezing water battery, overheating protectors or if the unit is stopped.

5.7. Maintenance interval reminder

When the maintenance interval is complete, the respective information is displayed on the operating panel and the indication light blinks green. The user can reset the reminder after the filters have been changed. The maintenance interval counter is reset and the new alert will be transmitted after the period has been completed again. The maintenance interval can be set between 3 - 12 months.

5.8. Filter-dirty notice

Differential pressure switch can be installed to the equipment that measures dirtiness of the inlet air filter by monitoring its differential pressure. When the switch runs, the display transmits the necessity of filter-change and the indication light blinks yellow. Differential pressure switch is taken into use through the maintenance menu and it deactivates maintenance interval reminder



For producing good indoor climate continuously, the air exchange systems require regular maintenance.

The metallic grease filter of stove hood must be kept clean at all times for fire safety reasons. Cleansing with hot water or in a dishwasher once a month is absolutely unavoidable. Substances suitable for machine washing may darken the aluminium parts of the filter.

Filter bags of fresh and extract air have to be regularly pulled out and replaced if needed. The pollen filter should be changed every summer. When installing the filters, it should be checked that they are in place and tightly secured with springs to the silicon sealing to avoid a bypass flow.

The summer cassette plate will be set to summer mode when the external air should come in fresh and clean.

LTO-exchanger will be pulled out of the unit and washed thoroughly in autumn just before the heating season begins - the heat recovery will then be at its best.

Check the condition of sealing and push the transmission back to its place.

The noise deductors above the impellers can also be detached for washing if necessary.

The inner painted walls of the unit are easy to clean. Check the condition of sealing, clean the outlet hose of condensing water and make sure the water flows freely and without any obstructions.

The impellers, air exchange adjusters and thermostats are components that do not require regular maintenance. Electrical works can be carried out only by a qualified electrician.

MAJFUNCTIONS AND FAULT ALERTS

NO SUCTION BY OUTLET AIR IMPELLERS AND / OR INLET AIR IMPELLERS DO NOT BLOW AIR.

IS / ARE ???

IF NOT !!!

The air conditioner switched on

Switch on the air exchange

The conditioner adjuster in position 2

Try working with position 3-4. Check the normal functioning mode

Air exchange unit's fuse in the electrical chart undamaged

Replace the fuse or turn it on

The impellers in the right position and pre-set

Ask the installer, check the records

The filters and lto-elements clean

Clean according to the instructions

The external air grate clogged

Clean the grate
Remove the insect-net

The external air too cold and the unit is set on just chilly

Freezing cover has stopped the inlet impeller

INLET AIR IS COLD

IS / ARE ???

IF NOT !!!

The post-heating of the inlet air turned on

Turn the post-heating on or set the inlet air index value higher

The heat recovery unit frozen

Check, turn on the fusion phase

Post-heating resistance overheat protection working

Open and reset the protection

CHECKING THE FUNCTIONING OF OUTLET AND INLET IMPELLERS

Stop the machine, open the door fastened with four star dogs.

In winter, you should let the machine to cool for a moment.

Use the machine on slow speeds, state the speed changes.

DO NOT TOUCH THE IMPELLER WINGS WHEN THEY ARE MOVING !!

The performance of inlet impeller is decreased or stopped by the freeze-alert thermostat when the temperature of the exhaust air reduces below set value (5c).

The inlet impeller starts again when the temperature of the exhaust air rises above the set value.

The channels must be checked if the impeller works but the air exchange is inadequate or the temperature changes in the channels between the interior and the machine. Temperature changes and humidity concentration in channels must be prevented by improving the isolation.

During harsh frosts in winter, the equipment must be used on lower speed so the post-heating will last and there will be no draught. Under extreme conditions (humidity / harsh cold) the lto-element may freeze over and the anti-freeze protection series are not able to defrost it. If such a case occurs, the machine has to be stopped, opened and the cold flow stopped and the ice given the necessary time to melt. Check the drainage of condensing water!

In case the water-lock dries out and makes pulping noise, you can

pour a drop or two of cooking oil.

In really cold weather, the head recovery unit heats the preheated inlet air with post-heating. The functionality can be proved by comparing the temperature of inlet air to the set value of the inlet air post-heating.

heating of resistance can also be stated by careful checking from the open machine running on slow speed.

The overheat protection has been activated in case the barrier temperature has risen +90 C (for instance, in case of power failure). Reset the overheat temperature by pressing the switch under the threaded contact protection.

Ask a qualified electrician to check the wiring.

PLEASE REFER TO DEEKAX MAINTANENCE SERVICE FOR ANY FURTHER INFORMATION OR ASSISTANCE



DEEKAX

PURE JOY FROM INDOOR AIR!

NOTES

DEEKAX Air Oy

Patruunapolku 4
79100 LÉPPÄVIRTA

Puh. 0207 912550